

**iQ700, Built-in washing machine,  
8 kg, 1400 rpm  
WI14W502GB**



iSensoric fully integrated premium built-in washing machine with iQdrive and timeLight.

- ✓ speedPack L – Speed up your programmes, or wash in just 15 minutes.
- ✓ LED simple touch display - easy to use and shows all relevant information clearly
- ✓ timeLight: See the programme status as a projection on the floor
- ✓ Outdoor/ Waterproofing programme – Protects waterproof textiles.
- ✓ Efficient, quiet, and durable with guarantee - iQdrive with 10 year guarantee

Energy Efficiency Class: ..... C  
 Weighted energy consumption in kWh per 100 washing cycles of eco 40-60 programme: ..... 62 kWh  
 Maximum capacity in kg: ..... 8.0 kg  
 The water consumption of the eco programme in liters per cycle: 45 l  
 Duration of eco 40-60 programme in hours and mins at rated capacity: ..... 3:26 h  
 Spin-drying efficiency class of eco 40-60 programme: ..... B  
 Airborne acoustical noise emission class: ..... A  
 Airborne acoustical noise emissions : ..... 66 dB(A) re 1pW  
 Built-in / Free-standing: ..... Built-in  
 Dimensions of the product: ..... 818 x 596 x 544 mm  
 Weight: ..... 72.1 kg  
 Connection Rating: ..... 2300 W  
 Fuse protection: ..... 10 A  
 Nominal power: ..... 220-240 V  
 Frequency: ..... 50 Hz  
 Length electrical supply cord: ..... 210.0 cm  
 Door opening: ..... Left  
 Wheels: ..... No  
 EAN code: ..... 4242003922132  
 Installation type: ..... Fully integrated



WX975600	Floor securing component
WZ10131	Extension for cold water inlet /Aquastop
WZ30400	Height-adjustable feet

## iQ700, Built-in washing machine, 8 kg, 1400 rpm WI14W502GB

### Performance

- Energy Efficiency Class<sup>1</sup>: C
- Energy<sup>2</sup> / Water<sup>3</sup>: 62 kWh / 45 litres
- Load capacity: 1 - 8 kg
- Programme duration<sup>4</sup>: 3:26 h:min
- Spin drying efficiency class: B
- Spin speed<sup>\*\*</sup>: 400 - 1400 rpm
- Noise level: 66 dB (A) re 1 pW
- Noise efficiency class: A
- Fully integrated

### Programmes/functions

#### Key features

- Touch control buttons: prewash, Ready in, temperature selection, varioSpeed, start/pause with reload function, Water & Rinse Plus, spin speed selection

#### Additional features

- Reload Function: Stop the washing machine to add any forgotten items of laundry to the drum.
- Large display for programme progress indication, temperature, spin speed, remaining time, 24 hours end time delay and load recommendation
- Timelight: See the programme status projected on the floor despite being built in
- iQdrive with 10 year warranty
- iQdrive with 10 year warranty
- aquaStop: Siemens home appliance with lifetime warranty against water damage\*
- waterPerfect Plus: water management system
- drum clean with reminder function
- autoLoad Plus
- Foam detection system
- Out of balance load adjustment
- Noise insulation: bottom cover
- antiVibration Design - for more stability and quietness
- Detergent dispensing: easy clean
- Divider for Liquid Detergent
- End of cycle buzzer
- Large white door with 130° opening and 30 cm porthole
- Furniture door is reversible
- Metal door catch

#### Technical Information

- adjustable base height: 15 cm
- adjustable base depth: 6.5 cm
- Height adjustment with cardanDrive

<sup>1</sup> Scale of Energy Efficiency Classes from A to G

<sup>2</sup> Energy consumption in kWh per 100 cycles (in programme Eco 40-60)

<sup>3</sup> Weighted water consumption in litres per cycle (in programme Eco 40-60)

<sup>4</sup> Duration of Eco 40-60 programme

\*\* Values are rounded.

\* Please find warranty terms under the additional warranties section of our website.

**iQ700, Built-in washing machine,  
8 kg, 1400 rpm  
WI14W502GB**

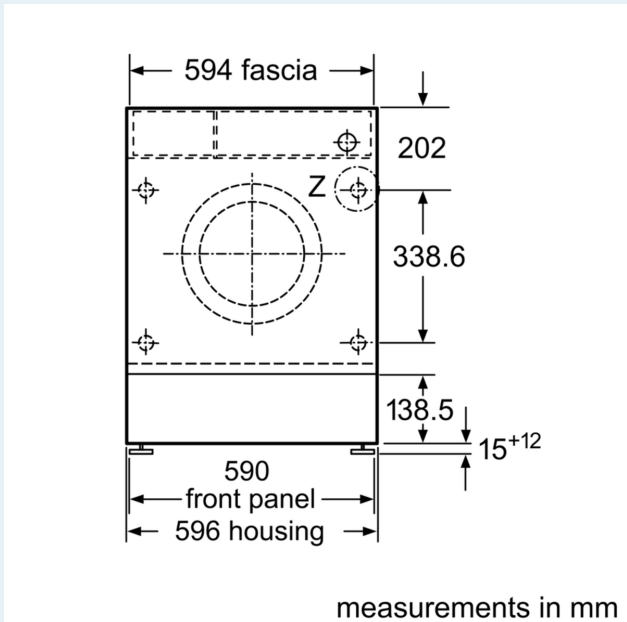
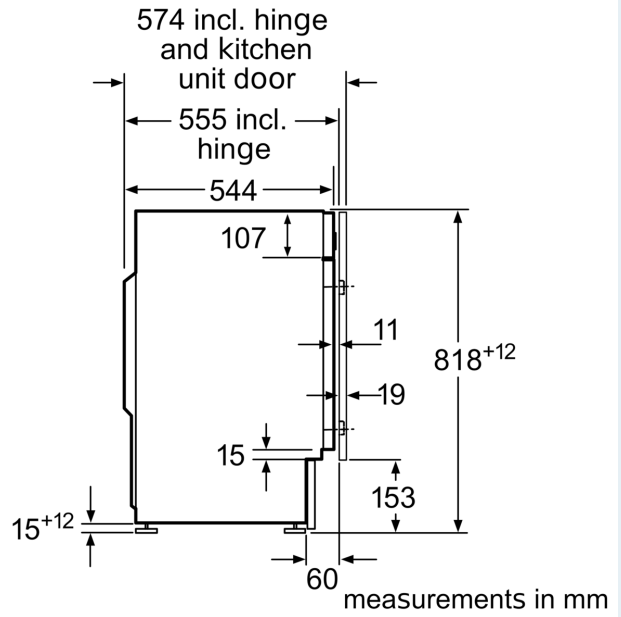
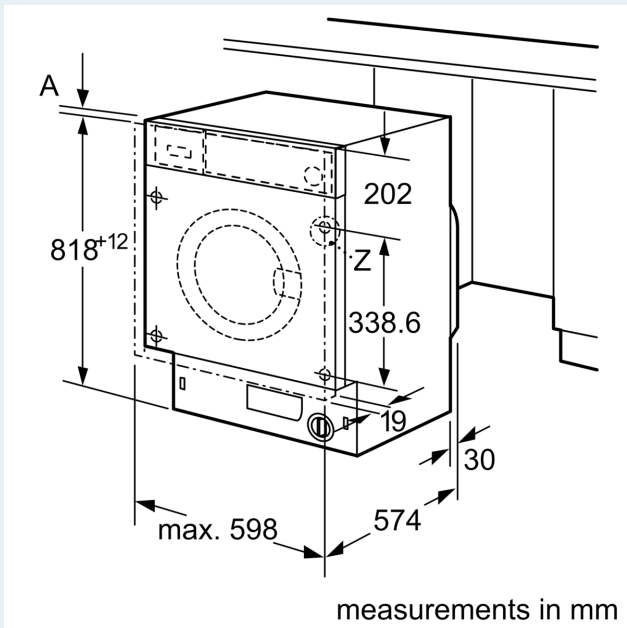

Z detail

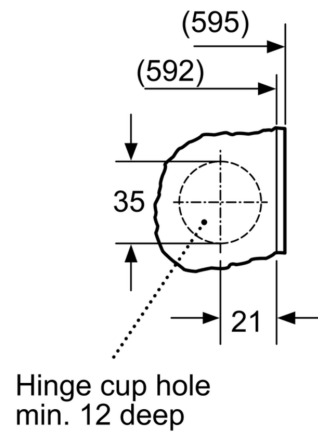

measurements in mm