

**iQ500, Canopy cooker hood, 70 cm, Black  
LB77NAC60B**



The powerful canopy cooker hood is seamlessly concealed in the upper cupboard or a brick chimney.

- ✓ Intensive setting revert - Peak performance when steam escapes, and an automatic revert after a few minutes.
- ✓ The canopy hood seamlessly integrates within the upper cabinet and becomes almost invisible, thanks to its flush installation design.
- ✓ pushbutton control: hassle-free cooking with low-lift push buttons
- ✓ Illuminate your cooking space with LED lights for optimal visibility and ambience setting.

LZ10ITP00	Long Life odor filter (replacement)
LZ11ITD11	Long Life recirculation kit external
LZ11IXB16	Clean Air Plus odor filter (replacement)
LZ11IXC16	Clean Air Plus recirc. kit external
LZ55651	Standard odor filter (replacement)
LZ55750	Standard recirculation kit

Typology:	Built-in/Built-under
Length electrical supply cord:	150.0 cm
Min. required niche size for installation (HxWxD):	345mm x 676.0mm x 264mm mm
Height of the appliance:	345 mm
Minimum distance above an electric hob:	500 mm
Minimum distance above a gas hob:	650 mm
Weight:	12.2 kg
Control panel:	Electronic
Number of speed settings:	3-stages + intensive setting
Maximum output air extraction:	595 m³/h
Boost position output recirculating:	705 m³/h
Maximum output recirculating air:	580 m³/h
Boost position air extraction:	730 m³/h
Maximum Air flow:	595 m³/h
Number of lights:	2
Noise level:	63 dB(A) re 1pW
Diameter of air outlet:	120 / 150 mm
Grease filter material:	Washable aluminium
EAN code:	4242003959909
Connection Rating:	252 W
Fuse protection:	3 A
Nominal power:	220-240 V
Frequency:	60; 50 Hz
Plug type:	GB plug
Installation type:	Built-in



## iQ500, Canopy cooker hood, 70 cm, Black LB77NAC60B

### Design:

- Canopy hood
- Installation: Cabinet
- Flush-fitted installation for a seamless integration in wall cupboards.
- Suitable for ducted and re-circulating operation
- For recirculated extraction various recirculation kits are available as optional accessories.

### Core Features:

- 2 x 1W LED lights
- Colour Temperature: 4000 K
- Light Intensity: 400 lux
- Capacitor motor
- 2 metal grease filter(s).

### Comfort Features:

- Soft touch button control with Electronic display
- 3 x power levels plus intensive setting
- Automatic reset from intensive to normal setting after 6 min

### Cleaning Comfort:

- Steel filter cover dishwasher-safe
- Easy to clean smooth surfaces and materials.

### Performance Exhaust:

- According to EN 61591 and EN/ IEC 60704-2-13 your appliance can achieve the following values in exhaust mode: Speed 1: extraction rate 270 m<sup>3</sup>/h; noise level 45 dB (A) re1pW Speed 2: extraction rate 400 m<sup>3</sup>/h; noise level 53 dB (A) re1pW Speed 3: extraction rate 595 m<sup>3</sup>/h; noise level 63 dB (A) re1pW Intensive 1: extraction rate 730 m<sup>3</sup>/h; noise level 68 dB (A) re1pW
- Energy Efficiency Class: A (at a range of energy efficiency classes from A+++ to D)
- Average Energy Consumption: 55.5 kWh/year\*
- Blower Efficiency Class: A\*
- Lighting Efficiency Class: A\*
- Grease Filtering Efficiency Class: D\*

### Performance Recirculation:

- According to EN 61591 and EN/ IEC 60704-2-13 your appliance can achieve the following values in recirculation mode with standard recirculation kit (available as optional accessory): Speed 1: extraction rate 250 m<sup>3</sup>/h; noise level 65 dB (A) re1pW Speed 2: extraction rate 350 m<sup>3</sup>/h; noise level 71 dB (A) re1pW Speed 3: extraction rate 400 m<sup>3</sup>/h ; noise level 74 dB (A) re1pW Intensive Speed 1: extraction rate 430 m<sup>3</sup>/h; noise level 75 dB (A) re1pW
- According to EN 61591 and EN/ IEC 60704-2-13 your appliance can achieve the following values in recirculation mode with Clean Air plus recirculation kit, for chimless installation (available as optional accessory): Speed 1: extraction rate 260 m<sup>3</sup>/h ; noise level 53 dB (A) re1pW Speed 2: extraction rate 385 m<sup>3</sup>/h ; noise level 71 dB (A) re1pW Speed 3: extraction rate 580 m<sup>3</sup>/h ; noise level 70 dB (A) re1pW Intensive Speed 1: extraction rate 705 m<sup>3</sup>/h ; noise level 73 dB (A) re1pW

### Technical Information and Sustainability:

- Consumption data:
- Power rating: 252 W
- Voltage: Nominal voltage: 220 - 240 V
- Sustainability:
- Environmentally friendly packaging
- Available odour filter as regenerative Long Life filter with 10 years lifetime

### Planning and Installation Information:

- Dimensions (HxWxD): 345 x 700 x 282 mm
- Dimensions recirculating (HxWxD): 345-345 x 700 x 282 mm
- Built-in dimensions (HxWxD): 345 x 676 x 264 mm
- Please reference the built-in dimensions provided in the installation drawings
- Electrical cable length 1.5 m
- Diameter pipe Ø 150 mm (Ø 120 mm enclosed)
- Back-pressure flap: Yes

iQ500, Canopy cooker hood, 70 cm, Black  
LB77NAC60B

Measurements in mm

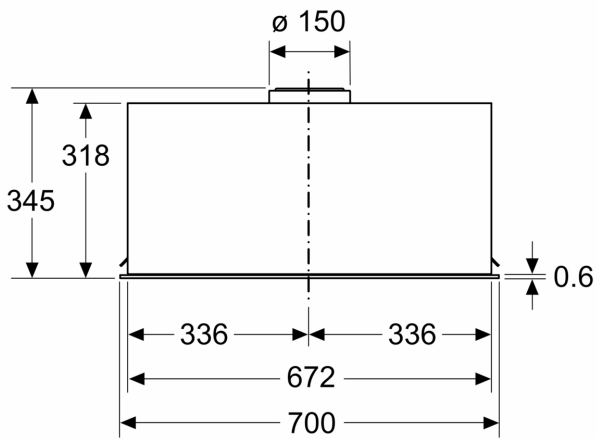

Measurements in mm

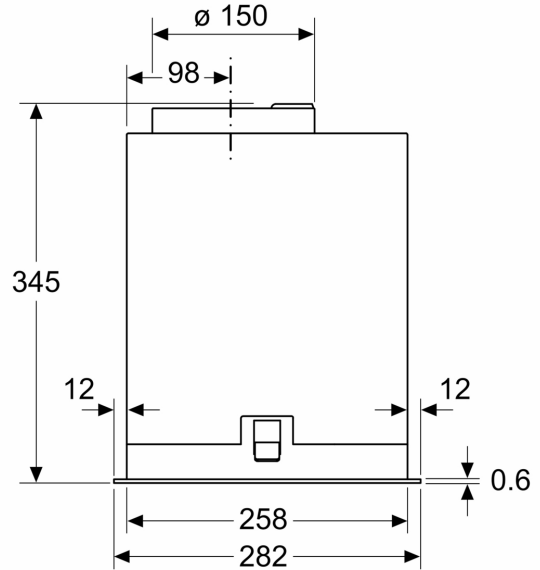

Measurements in mm

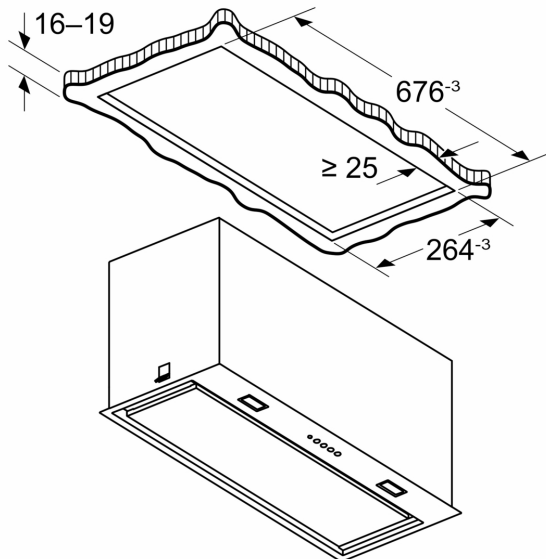

Measurements in mm

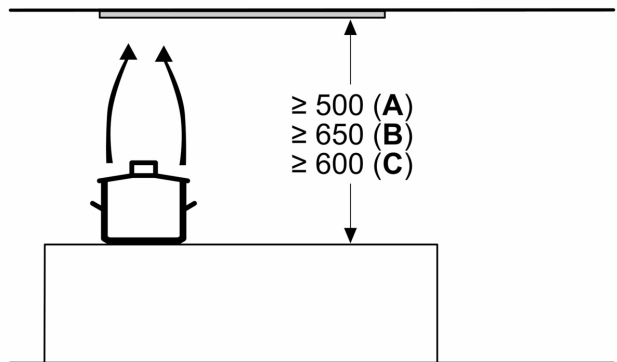

- A: Electric
- B: Gas - from upper edge of pan support
- C: Electric - for Australia and New Zealand