

**Series 4, Built-in freezer, 177.2 x 55.8 cm, flat hinge  
GIN81VEE0G**



1 x ice cube tray

KSZB0S00 Heavy-duty hinge support

**This NoFrost built-in freezer needs no defrosting and features a malfunction warning signal in case of increasing temperature.**

- An audible alarm system signals the door is open
- VarioZone: more flexibility due to variable-use glass shelves and drawers in the freezer compartment.
- NoFrost: never defrost again, thanks to perfect protection from ice formation - that saves time and effort.
- Big Box drawer: easily stack food containers and store larger items in your freezer.
- Intelligent Inverter Technology: ensuring stable temperature control and efficient performance.

Energy Efficiency Class: .....	E
Average annual energy consumption in kilowatt hour per year (kWh/a): .....	235 kWh/annum
Sum of volume of frozen compartments: .....	212 l
Airborne acoustical noise emissions : .....	35 dB(A) re 1pW
Airborne acoustical noise emission class: .....	B
Thermometer freeze section: .....	Digital
Light: .....	No
Product category: .....	Upright freezer
Built-in / Free-standing: .....	Built-in
Door panel options: .....	Not possible
Frost free system: .....	Fridge and freezer
Height of the appliance: .....	1772 mm
Width of the appliance: .....	558 mm
Depth: .....	545 mm
Dimensions of the packed product (HxWxD): ...	1840 x 610 x 640 mm
Net weight: .....	64.0 kg
Gross weight: .....	68.7 kg
Fuse protection: .....	13 A
Frequency: .....	50 Hz
Length electrical supply cord: .....	230.0 cm
Door hinge: .....	Left reversible
Defrost process: .....	Automatic
Warning signal / malfunction: .....	Both visual and audible
Door lock: .....	No
Number of drawers/baskets (Stck): .....	5
Number of freezing flaps (Stck): .....	2
EAN code: .....	4242005422098
Brand: .....	Bosch
Product name / Commercial code: .....	GIN81VEE0G
Product category: .....	Upright freezer
Included accessories: .....	1 x ice cube tray



## **Series 4, Built-in freezer, 177.2 x 55.8 cm, flat hinge GIN81VEE0G**

**This NoFrost built-in freezer needs no defrosting and features a malfunction warning signal in case of increasing temperature.**

- 
- No Frost, Built-in tall freezer
  - Fixed hinge

### **Performance and Consumption**

- EU19\_EEK\_D: E
- Total Volume : 212 l
- Annual Energy Consumption: 235 kWh/a
- EU19\_Fast freezer facility\_D
- Noise Level : 35 dB , EU19\_Noise emission class\_D: B

### **Functions**

- Fixed hinge

### **Design features**

- NO\_FROST\_NEU\_BL, never have to defrost ever again
- LED Electronic control
- SuperFreeze function with automatic deactivation
- Freezer malfunction warning signal: optical, acoustical

### **Food freshness system**

- Net Freezer Volume : 212 l
- Net 4\* compartment volume : 212 l
- Freezing capacity 24h : 13.8 kg
- Temperature rise time : EU19\_Temperature rise time\_D: 8 H
- 5 transparent freezer drawers, 2 BigBox
- 2 hinged freezer compartment
- Vario Zone - removable safety glass shelves for extra space!

### **Dimension and installation**

- Dimensions: 177.2 cm H x 55.8 cm W x 54.5 cm D
- Niche Dimensions: 177.5 cm H x 56 cm W x 55 cm D

### **Key features - Fridge section**

- Door left hinged, door reversible
- Climate Class: SN-T
- Length of power cord: 230 cm
- 220 - 240 V

### **Key features - Freezer section**

- ice cube tray

### **Country Specific Options**

- Based on the results of the standard 24-hour test. Actual consumption depends on usage/position of the appliance.

### **Additional features**

#### **Design features**

#### **Dimension and installation**

**Series 4, Built-in freezer, 177.2 x 55.8 cm, flat hinge**  
**GIN81VEE0G**

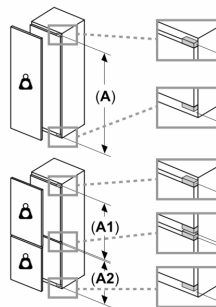
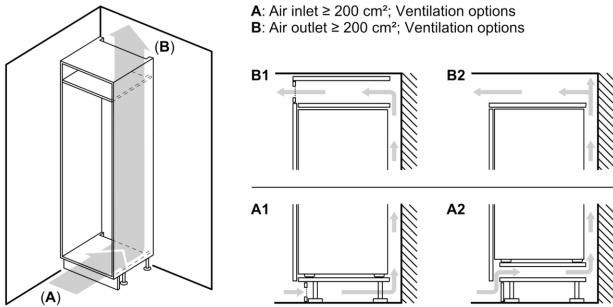

**Maximal permissible weight of the unit fronts**

Fitted unit fronts that exceed the permissible weight may cause damage and result in functional impairment of the hinges

$\Delta$ : Weight  
 A: Appliance door height including hinges in mm

B: Undamped hinge, unit front in kg

C: Damped hinge, unit front in kg

D: Additional possible load in kg with heavy load kit

A	B	C	D
1500-1750	22	22	B+5 / C+5
720-1400	19	19	
A1	15	19	
A2	15	19	

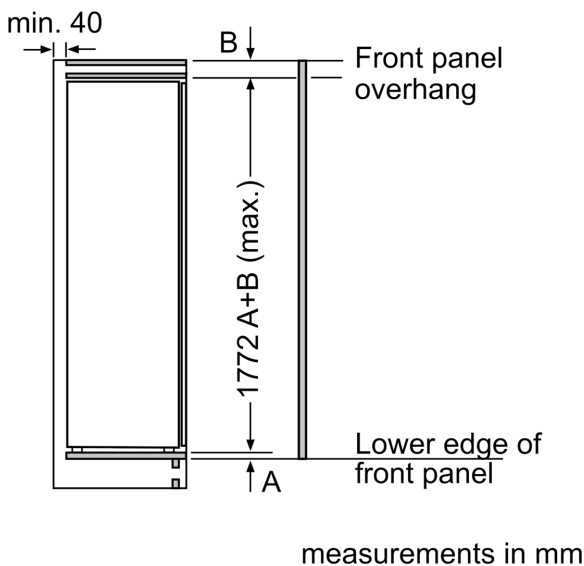
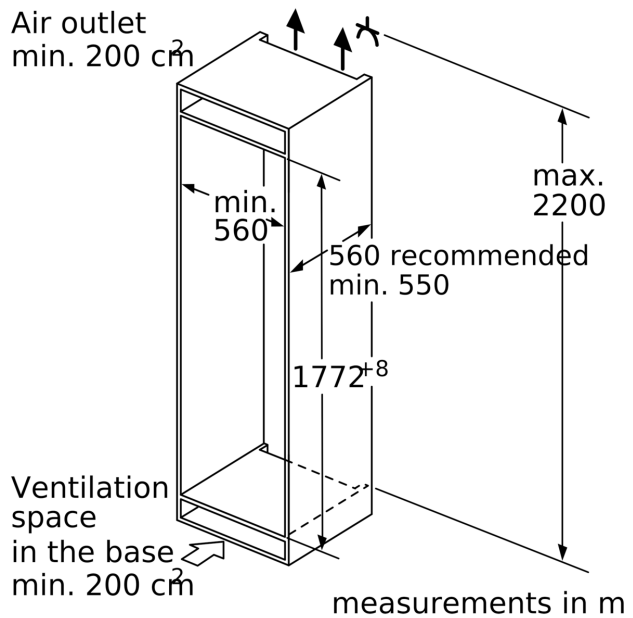
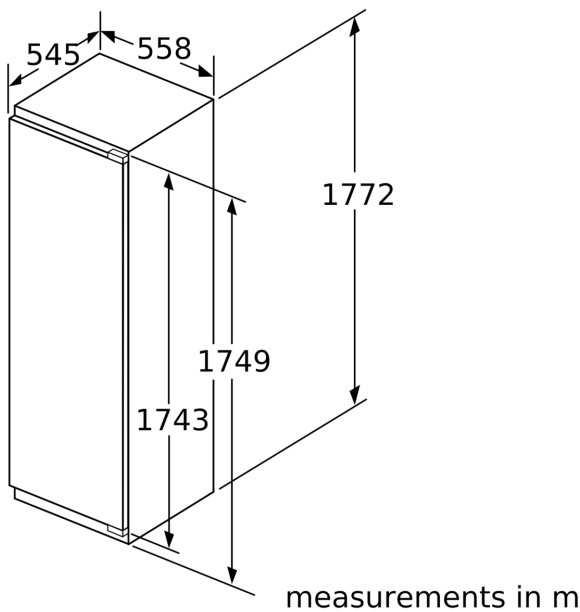

**Maximal permissible weight of the unit fronts**

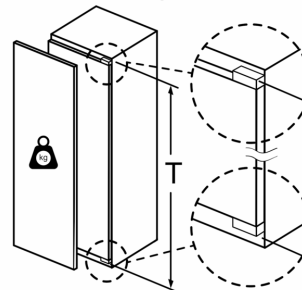

Fitted kitchen unit doors that exceed the permissible weight may cause damage and result in functional impairment of the hinges.

T: Includes height of appliance door	undamped hinge, Door in kg:	damped hinge, Door in kg:
Hinges in mm:		
1500-1750	22	22

measurements in mm  
 Recommended gap dimensions for flat hinges

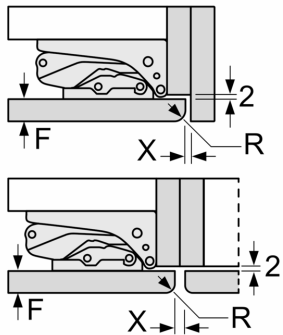

<b>F</b>	<b>R</b>	<b>X</b>
16-19	0-3	2.5
20	0-1	3
	2-3	2.5
21	0-1	3
	2-3	2.5
22	0	4
	1	3.5
	2-3	3

The gap dimensions recommended in the table must be adhered to in order to ensure that appliance doors do not collide with anything when they are opened, and to avoid causing damage to kitchen units.