

N 50, BUILT-IN FREEZER, 71.2 X 55.8 CM, FLAT HINGE
G1113FEO



1 x ice cube tray
KU1213Z0 Attachment door, stainless steel

This built-in freezer helps to defrost faster, comes with a malfunction warning signal and consumes very low energy only.

✓ Low Frost – Reduces frost in the freezer compartment for faster defrosting

Energy Efficiency Class:	E
Average annual energy consumption in kilowatt hour per year (kWh/a):	167 kWh/a
Sum of volume of frozen compartments:	72 l
Airborne acoustical noise emissions :	36 dB(A) re 1pW
Airborne acoustical noise emission class:	C
Thermometer freeze section:	None
Light:	No
Product category:	Upright freezer
Built-in / Free-standing:	Built-in
Door panel options:	Not possible
Frost free system:	No
Height of the appliance:	712 mm
Width of the appliance:	558 mm
Depth:	545 mm
Dimensions of the packed product (HxWxD): .	790 x 620 x 640 mm
Net weight:	35.6 kg
Gross weight:	38.0 kg
Connection Rating:	90 W
Fuse protection:	10 A
Frequency:	50 Hz
Length electrical supply cord:	230.0 cm
Door hinge:	Right reversible
Defrost process:	manual
Warning signal / malfunction:	Both visual and audible
Door lock:	No
Number of drawers/baskets (Stck):	3
Number of freezing flaps (Stck):	0
EAN code:	4242004239628
Brand:	Neff
Product name / Commercial code:	G1113FEO
Product category:	Upright freezer
Included accessories:	1 x ice cube tray



N 50, BUILT-IN FREEZER, 71.2 X 55.8 CM, FLAT
HINGE
G1113FEO

Functions

- Fixed hinge
- Fixed hinge

Design features

- lowFrost freezer - less ice build up, faster defrosting
- SuperFreeze function with automatic deactivation
- Electronic control (LED chain)
- Freezer malfunction warning signal: optical, acoustical

Dimension and installation

- Right hinged door, reversible
- Connection value 90 W
- 220 - 240 V
- Dimensions: 71.2 cm H x 55.8 cm W x 54.5 cm D
- Niche Dimensions: 72 cm H x 56 cm W x 55 cm D

Food freshness system

Key features - Freezer section

- Freezing possible in all freezer compartments
- Manual defrost freezer
- 3 freezer drawers
- ice cube tray

Included accessories

- KU1213Z0

Design features

Dimension and installation

- Based on the results of the standard 24-hour test. Actual consumption depends on usage/position of the appliance.

Additional features

Performance and Consumption

- EU19_EEK_D: E
- Total Volume : 72 l
- Net Freezer Volume : 72 l
- Net 4* compartment volume : 72 l
- Freezing capacity 24h : 4.4 kg
- Annual Energy Consumption: 167 kWh/a
- Climate Class: SN-T
- Noise Level : 36 dB , EU19_Noise emission class_D: C
- Temperature rise time : EU19_Temperature rise time_D: 13 H

N 50, BUILT-IN FREEZER, 71.2 X 55.8 CM, FLAT HINGE
G1113FE0

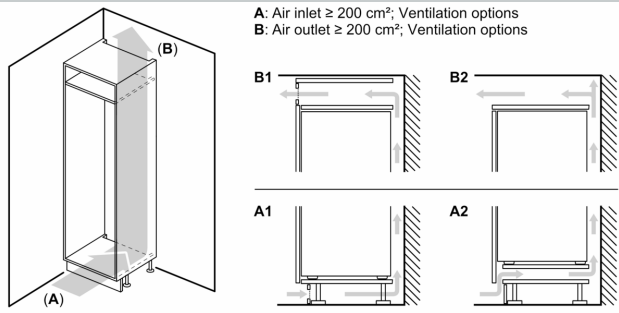

Maximal permissible weight of the unit fronts

Fitted unit fronts that exceed the permissible weight may cause damage and result in functional impairment of the hinges

Δ Weight
A: Appliance door height including hinges in mm
B: Undamped hinge, unit front in kg
C: Damped hinge, unit front in kg
D: Additional possible load in kg with heavy load kit

A	B	C	D
1500-1750	22	22	B+5 / C+5
720-1400	19	19	
A1	15	19	
A2	15	19	

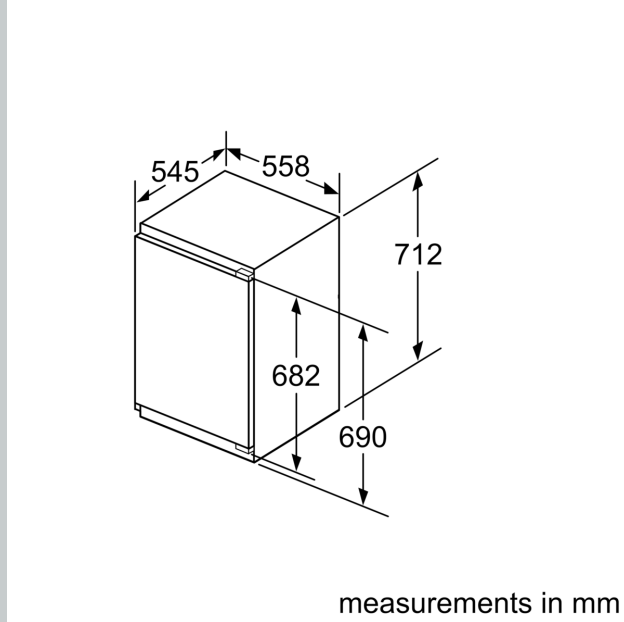
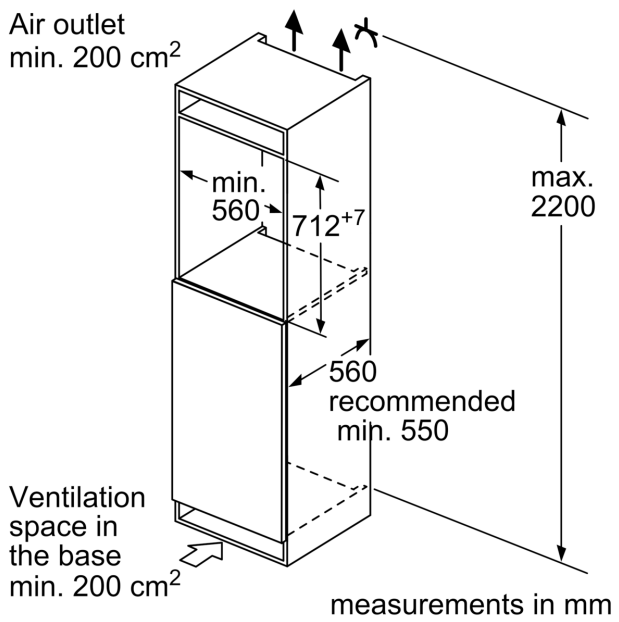

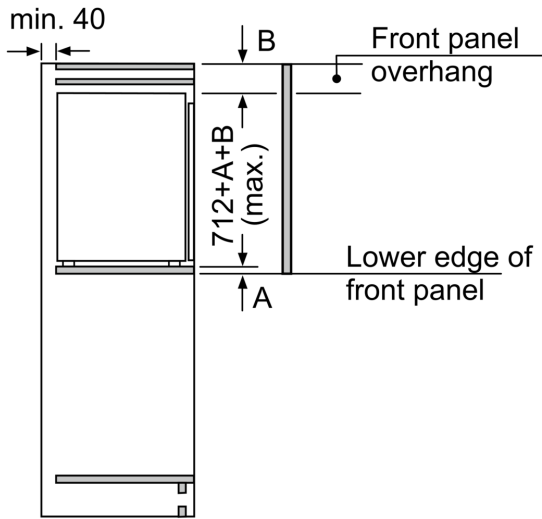

measurements in mm

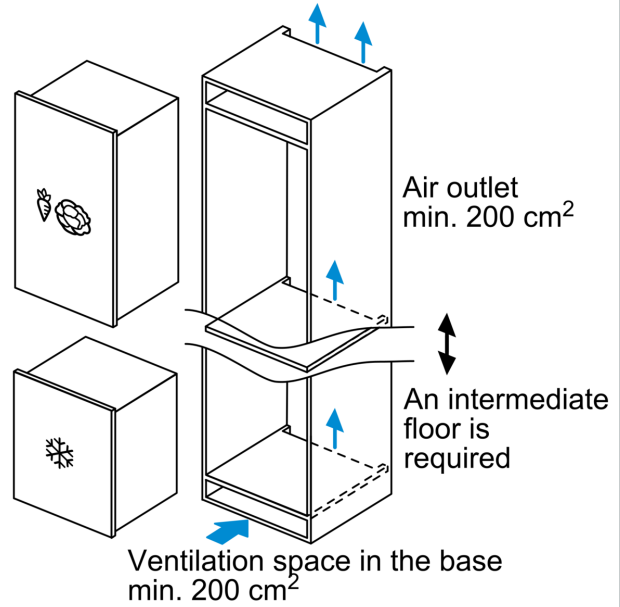

measurements in mm
Recommended gap dimensions for flat hinges

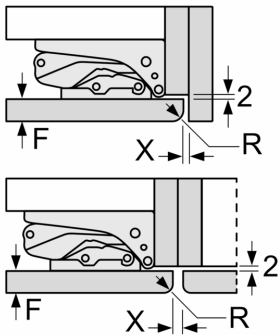

	F	R	X
16-19	0-3	2.5	
	20	0-1	3
21	2-3	2.5	
	21	0-1	3
22	2-3	2.5	
	22	0	4
		1	3.5
	2-3	3	

The gap dimensions recommended in the table must be adhered to in order to ensure that appliance doors do not collide with anything when they are opened, and to avoid causing damage to kitchen units.