

N 70, INTEGRATED DESIGN HOOD, 90 CM, CLEAR  
GLASS BLACK PRINTED  
D95XAM2SOB



**B**

Our invisible integrated design hood - perfectly integrated with extra storage for easy access items, such as spices and herbs.

- ✓ Hidden Design – Seamlessly integrate your hood in a flush fitted cupboard design
- ✓ Extra Storage Space – The hood's T-shaped design creates extra space for many large and handy items up to 10kg on each side
- ✓ Reduced Noise: our optimised motor guarantees a quiet cooking experience.
- ✓ Intensive speed setting: increases the extraction rate when the steam gets intense
- ✓ Comfort Control - Automatic recognition of the glass panel position switches your hood and light on/off. No need to open the kitchen cabinet to control your hood, lifting the glass panel is enough.

Z51IBK1S1	Chimney extension 450-854 mm
Z51IBN1S1	Chimney extension 187-360 mm
Z51ITD1X1	Long Life recirculation kit external
Z51ITP0X0	Long Life odor filter (replacement)
Z51IXB1X6	Clean Air Plus odor filter (replacement)
Z51IXC1X6	Clean Air Plus recirc. kit external
Z51IBB6X4	Clean Air Standard odor filter (repl.)
Z51IBI6X4	Clean Air Standard recirculation kit

Typology:	..... Built-in/Built-under
Length electrical supply cord:	..... 130.0 cm
Min. required niche size for installation (HxWxD):	..... 340mm x 860.0mm x 300mm mm
Minimum distance above an electric hob:	..... 430 mm
Minimum distance above a gas hob:	..... 650 mm
Net weight:	..... 10.4 kg
Type of control:	..... Electronic
Number of speed settings:	..... 3-stages + intensive setting
Maximum output air extraction:	..... 460 m <sup>3</sup> /h
Boost position output recirculating:	..... 652 m <sup>3</sup> /h
Maximum output recirculating air:	..... 451 m <sup>3</sup> /h
Boost position air extraction:	..... 749 m <sup>3</sup> /h
Maximum Air flow:	..... 460 m <sup>3</sup> /h
Number of lights:	..... 3
Noise level:	..... 63 dB(A) re 1pW
Diameter of air outlet:	..... 120 / 150 mm
Grease filter material:	..... Washable stainless steel
EAN code:	..... 4242004260103
Connection Rating:	..... 259 W
Voltage:	..... 220-240 V
Frequency:	..... 50 Hz
Plug type:	..... GB plug
Installation typology:	..... Built-in



N 70, INTEGRATED DESIGN HOOD, 90 CM, CLEAR  
GLASS BLACK PRINTED  
D95XAM2SOB

#### Variant

- 90 cm wide
- Installation: Cupboard 90 cm
- Suitable for ducted extraction and recirculation
- For recirculated extraction various recirculation kits are available as optional accessories.

#### Design

- Flush-fitted installation for a seamless integration in wall cupboards.
- Space efficient compact design for extra storage possibilities on the hood, up to max. 10 kg storage weight per side.
- Glass panel with touch control for an easy operation and enhanced vapor capture.
- Extraction and lighting are automatically turned on and off by opening and closing the glass panel.
- Lighting can also be turned on and off when the glass panel is closed by quick hand touch on control panel.
- Includes mats for hood storage areas, protection against scratches and to help prevent items moving in this space.

#### Features

- Electronic controls via Touch control
- 3 speeds plus intensive
- SoftLight with dimmer function
- 3 x 2 W LED lights
- Colour Temperature: 3500 K
- Light Intensity: 517 lux
- Automatic revert setting
- Automatic intensive revert (6mins)
- Stainless steel filter covers
- 2 metal grease filter cassettes
- Easy to clean smooth surfaces and materials.

#### Performance

- Extraction rate according to EN 61591 ø 15 cm:
- max. Normal use: 460 m<sup>3</sup>/h
- Intensive: 749 m<sup>3</sup>/h
- Noise level according to EN 60704-3 and EN 60704-2-13 exhaust air:
- Max. normal use: 63 dB(A) re 1 pW
- Intensive: 73 dB(A) re 1 pW
- Noise max. Normal Level: Noise, max. speed in normal use: 63 dB dB\*
- With the Clean Air Plus recirculation kit (available as optional accessory) your appliances reaches:
- Extraction rate in recirculation mode: Max. normal use: 451 m<sup>3</sup>/h
- Intensive: 652 m<sup>3</sup>/h
- Noise level in recirculation mode: Max. normal use: 67 dB(A) re 1 pW
- Intensive: 74 dB(A) re 1 pW

#### Planning and installation information

- Installation system: IDH comfort installation

- Suitable for installation in bottomless wall cupboards.
- Enclosed spacers for installation in wall cupboards with maximum depth of up to 360mm.
- For installation in higher wall cupboards chimney extensions are available as optional accessories.
- Chimney extensions are compatible with the available recirculation kits.
- Dimensions (HxWxD): 340 x 897 x 298 mm
- Built-in dimensions (HxWxD): 340 x 860 x 300 mm
- Diameter pipe Ø 150 mm (Ø 120 mm enclosed)
- Back-pressure flap: Yes
- Electrical cable length 1.3 m
- Please reference the built-in dimensions provided in the installation drawings

#### Consumption Data

- Energy Efficiency Class: B (at a range of energy efficiency classes from A+++ to D)
- Average Energy Consumption: 64.7 kWh/year\*
- Blower Efficiency Class: B\*
- Lighting Efficiency Class: A\*
- Grease Filtering Efficiency Class: B\*
- Power rating: 259 W

\* In accordance with the EU-Regulation No 65/2014

N 70, INTEGRATED DESIGN HOOD, 90 CM, CLEAR  
GLASS BLACK PRINTED  
D95XAM2SOB

measurements in mm  
**Front view**

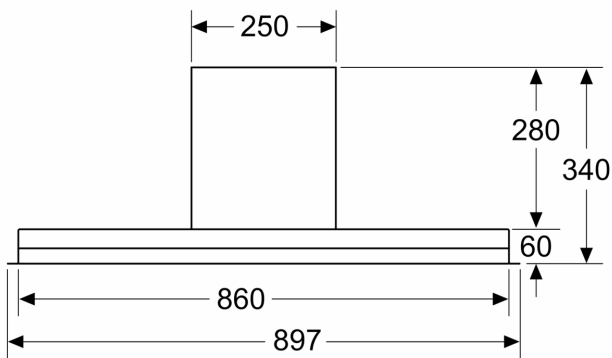

measurements in mm  
**Installation example**

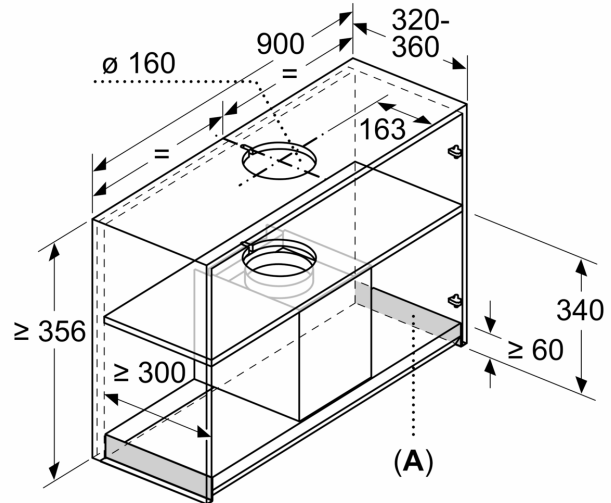

**A:** Area without hinges

measurements in mm

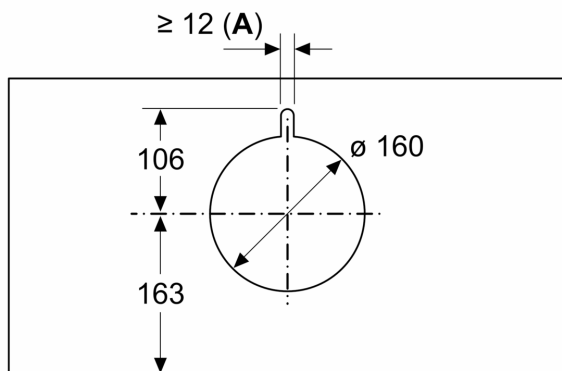

**A:** Cable bushing

measurements in mm

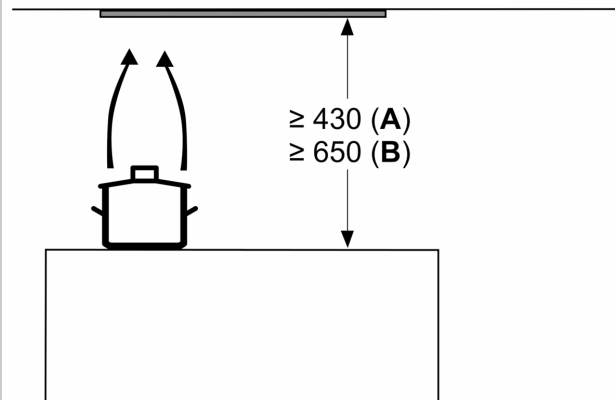

from upper edge of pan support

**A:** min. 430 electric

**B:** min. 650 gas

measurements in mm  
**side view**

